



TECNOSERVICE'21 srl

by Tinti Sergio
Via Carlo Pisacane, 134
61032 Fano (PU) Italy
P.IVA IT0200411413

Tel. +39 0721 805911
FAX +39 0721 809794
e-mail: staff@technochef.it
www.technochef.it
www.technochef.eu

Servizi e tecnologie per la ristorazione dal 1973 ... Services and Technologies for professional catering since 1973

CODICE	DESCRIZIONE	PREZZO/CONSEGNA
SI-IP20MAN	Impastatrice carne manuale in acciaio inox, capacità vasca 20 Kg, pala inox rimovibile, 2 velocità di impasto, Peso 13 Kg, dim.mm.400x340x403h	€ 668,13 + IVA Spedizione in Italia: compresa Consegna: da 8 a 15 giorni

DESCRIZIONE PROFESSIONALE

IMPASTATRICE CARNE MANUALE INOX con VASCA da 20 Kg, ideale per PICCOLI IMPASTI, sia in MACELLERIA che RISTORAZIONE:

- **Costruzione in acciaio inox Aisi 304;**
- **Pala in acciaio inox Aisi 304 facilmente rimovibile** senza attrezzi;
- **Riduttore con ingranaggi** temprati e rettificati;
- **Sistema di protezione ingranaggi** con doppio paraolio;
- **2 velocità di impasto:**
 - 1:1 in presa diretta con la pala
 - 1:3 per impasti più tenaci.
- **Pratica e compatta.**

DATI TECNICI:

- Dimensioni vasca: mm 270x300
- Capacità: lt 28 / kg 20
- Peso netto: kg 13
- Dimensioni: 400x340x403mm

Marchio CE
Made in ITALY

SCHEDA TECNICA	
Peso netto (Kg)	13
Larghezza (mm)	400
Profondità (mm)	340
Altezza (mm)	403





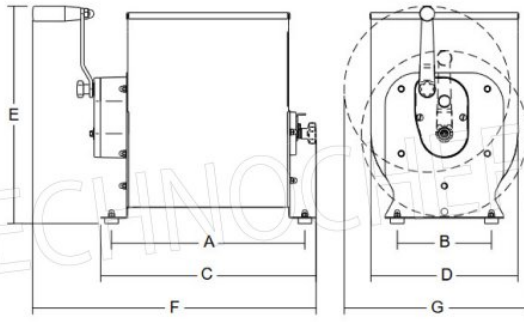

											
	mm	h/kg	mm	mm	mm	mm	mm	mm	mm	kg	kg
IP 20 Man	270-300	28/20	360	175	400	273	403	527	340	13	23