



SCHEDA TECNICA

Peso netto (Kg)	49
Peso lordo (Kg)	59
Larghezza (mm)	680
Profondità (mm)	365
Altezza (mm)	530

DESCRIZIONE PROFESSIONALE

IMPASTATRICE CARNE INOX con VASCA da 30 Kg:

- Costruzione in **acciaio inox Aisi 304**;
- **Pala in acciaio inox Aisi 304** facilmente **rimovibile** senza attrezzi;
- **Potente motore Hp 2**;
- Riduttore a bagno d'olio con ingranaggi elicoidali temperati e rettificati;
- **Sistema di protezione ingranaggi** con doppio paraolio;
- Coperchio con **micro di sicurezza**;
- **Sportello vasca apribile** per rimozione pala e impasto;
- Comandi IP54 con inversione;
- **Disponibile in versione Monofase o Trifase.**

DATI TECNICI:

- Potenza: 1ph watt 1100/Hp 1,5 - 3ph watt 1472/Hp 2
- Alimentazione: 230 /400 V
- Dimensioni vasca: mm 300x400
- Capacità vasca: lt 42 - kg 30
- Dimensioni: 680 x 365 x 530 mm
- Peso netto: 49 kg
- Peso lordo: 59 kg

Accessori/Optional:

- Gambe inox basse, medie e alte con ruote

◦ Tramoggia aggiunta ingredienti

Marchio CE
Made in ITALY

MODELLI DISPONIBILI

SI-IP30M/T



Impastatrice carne in acciaio inox, capacità vasca 30 Kg, pala inox rimovibile, V.400/3, Kw.1,472, Peso 49 Kg, dim.mm.680x365x530h

€ 1.928,63 + IVA

€ 2.352,93 IVA incl.

Spedizione in Italia: compresa

Consegna: da 8 a 15 giorni

SI-IP30M/M



Impastatrice carne in acciaio inox, capacità vasca 30 Kg, pala inox rimovibile, V.230/1, Kw.1,1, Peso 49 Kg, dim.mm.680x365x530h

€ 1.942,40 + IVA

€ 2.369,73 IVA incl.

Spedizione in Italia: compresa

Consegna: da 8 a 15 giorni

ACCESSORI/OPTIONAL

CODICE/FOTO

DESCRIZIONE

PREZZO/CONSEGNA

SI-TRM



SIRMAN - Tramoggia per aggiunta ingredienti

€ 19,34 + IVA

€ 19,34 IVA incl.

Spedizione in Italia: compresa

Consegna: da 3 a 6 giorni

SI-GBP



SIRMAN - Gambe basse con piedino

€ 154,57 + IVA

€ 188,58 IVA incl.

Spedizione in Italia: compresa

Consegna: da 4 a 9 giorni

SI-GMR



SIRMAN - Gambe medie con ruote

€ 292,19 + IVA

€ 356,47 IVA incl.

Spedizione in Italia: compresa

Consegna: da 4 a 9 giorni

SI-GAR/30



SIRMAN - Gambe alte con ruote

€ 484,90 + IVA

€ 591,58 IVA incl.

Spedizione in Italia: compresa

Consegna: da 4 a 9 giorni



TECHNOCHEF.IT



TECHNOCHEF.IT



Gambe con ruote opzionali



Opzione tramoggia per aggiunta
ingredienti
Optional feed tray for add ingredients

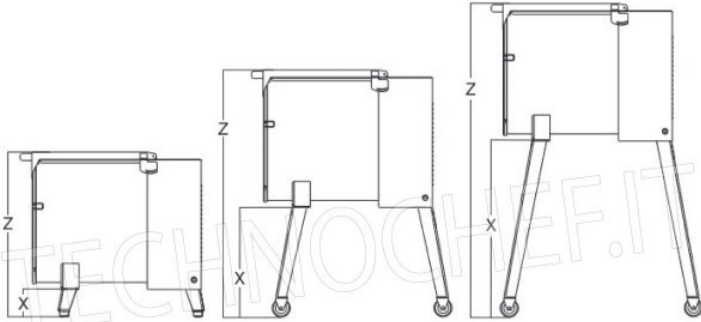

Gambe opzionali / Optional legs

Gambe basse + piedino
Short legs + feet

Gambe medie+ruote+freno
Medium legs+wheels+brake

Gambe alte+ruote+freno
Longer legs+wheels+brake

IP 30 M Y14

X: 150 mm / Z: 650 mm

IP 30 M Y14

X: 440 mm / Z: 940 mm

IP 30 M Y14

X: 610 mm / Z: 1110 mm

IP 50 M Y14

X: 150 mm / Z: 720 mm

IP 50 M Y14

X: 440 mm / Z: 1010 mm

IP 50 M Y14

X: 610 mm / Z: 1180 mm

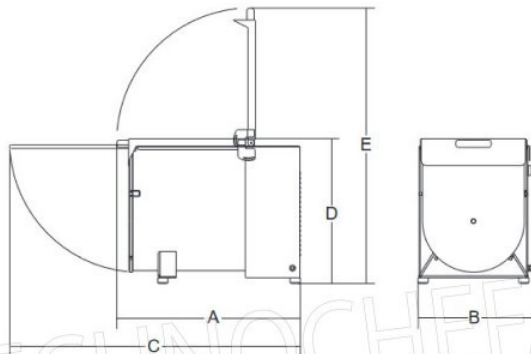

					A	B	C	D	E			
	width	height	mm	h/kg	mm	mm	mm	mm	mm	kg	mm	kg
IP 30 M Y14	1ph 1.100/1.5 3ph 1.47/2/2	1ph/3ph	300x400	42/30	680	365	1120	530	975	49	750x580x800	59
IP 50 M Y14	1ph 1.100/1.5 3ph 1.47/2/2	1ph/3ph	410x480	88/50	750	465	1250	595	1120	59	850x640x830	74